





BIO BASIC Worldwide



For more information on pricing, complete product line or to locate a Point of Sales near you, please visit our website or contact one of our Customer Service Representatives.

Email  order@biobasic.com
Phone  1 (905) 474-4493
Toll Free  1 (800) 313-7224
Fax  1 (905) 474-5794



EZ-10 96 Well Spin Column
Plasmid DNA Mini-Preps Kit

B814152-002 (2 Plates)
B814152-005 (5 Plates)
QF 24 TV4
CV1 2020

For Research Use Only

EZ-10 96 Well Spin Column Plasmid DNA Mini-Preps Kit

**Code: B814152-002 (2 Plates)
B814152-005 (5 Plates)**

Description.....	1
Kit Contents.....	2
Features.....	3
Storage.....	3
Quality Control.....	3
Procedures.....	4-9
Troubleshooting.....	9
Other Kits Available.....	10

Description

The EZ-10 96 Well Spin Column Plasmid DNA Purification kit provides a simple, efficient and automated high throughput method for plasmid DNA purifications. Plasmid DNA is selectively adsorbed in silica gel-based EZ-10 columns in the 96 Well Binding Plate and other impurities such as proteins, salts and nucleotides are removed. Plasmid DNA can be eluted in a small volume of Tris buffer.

NOTE: This kit is used for preparation of up to 10 µg of pure plasmid DNA in each well.

Other Kits Available

- **EZ-10 Spin Column Plasmid DNA MiniPreps Kit**
BS413 (50 preps), BS414 (100 preps)
- **EZ-10 Spin Column PCR Products Purification Kit**
BS363 (50 preps), BS364 (100 preps)
- **EZ-10 Spin Column DNA Gel Extraction Kit**
BS353 (50 preps), BS354 (100 preps)



PRODUCTS ARE FOR SCIENTIFIC RESEARCH ONLY
NOT INTENDED FOR HUMAN OR ANIMAL USE

- 19. Note:** It is important to add the Elution Buffer into the center of each well. For optimal results, incubate plate with elution buffer at 60°C for 15 minutes prior to applying vacuum.

Troubleshooting

1. RNA Contamination

- A.** RNase A digestion might be insufficient. Check the culture volume against recommended volumes, and adjust if necessary. If RNaseA solution is kept for more than 6 months, add more RNase A.
- B.** Prolong the standing time after adding supernatant to the EZ-10 96 Well Binding Plate.
- C.** Incubate the EZ-10 96 Well Binding Plate at 60°C for 3–5 minutes after adding the Elution Buffer.

2. Low Yield of Plasmid DNA

Alkaline lysis is inefficient: If cells have grown to a very high density, the ratio of biomass to lysis reagent is shifted. This may result in poor lysis conditions. Reduce culture volume or increase volumes of Solution I, II and III.

- 3.** For optimal results in downstream DNA sequencing, an additional washing step is recommended.

Kit Contents

Components	B814152-002 (2 Plates)	B814152-005 (5 Plates)
RNase A (10mg/ml)	0.5 ml	1.2 ml
Solution I*	25 ml	60 ml
Solution II**	50 ml	120 ml
Solution III	90 ml	210 ml
Wash Solution***	2 x 40 ml	5 x 40 ml
Elution Buffer****	15 ml	30 ml
EZ-10 96 Well Binding Plate-Vacuum Manifold Fit	2	5
96 Well Filter Plate	2	5
Deep Well Collection Plate	4	10
96 Well Storage Plate	2	5
Sealing Film	10	25
Protocol	1	1

*Before use, add RNase A to Solution I. Solution I should be stored at 4°C for frequent use, or at -20°C for long term storage.

**Solution II may form a precipitate upon storage. If necessary, dissolve the precipitate by warming at 37°C.

***Before use, add 160 ml of 96-100% of ethanol to 40 ml Wash Solution. If the volume of Wash Solution has changed due to leaking during transportation, it is necessary to re-measure its volume, and adjust the volume of required ethanol accordingly (volume of added ethanol: volume of Wash Solution=4:1).

**** Elution Buffer is 2.5 mM Tris-HCl pH8.0~8.5. Although TE buffer pH 8.0 or water can be used, yield is generally 20% lower.

Features

- Fast: Entire procedure takes approximately 45 minutes.
- High quality: Purified DNA can be used in any downstream applications such as sequencing, transformation, restriction enzymatic digestion, and ligation.
- High yield (>80%) and reproducible.
- Convenient and environmentally friendly. No phenol/chloroform extraction or ethanol precipitation required.

Storage

With the exception of the RNase A, the kit may be stored at room temperature. The RNase A should be stored at 4°C. The kit is stable for 12 months at room temperature. For longer storage, keep all contents in cold place.

Quality Control

All components in the kit are tested in purification of 96 x 10 µg pUC18 plasmid DNA from overnight culture.

12. Repeat step 11 two times.
13. After Wash Solution has been drawn through all wells, apply maximum vacuum for an additional minute to dry the membrane.
14. Switch off the vacuum and ventilate the vacuum manifold slowly. Remove the EZ-10 96 Well Binding Plate together with the Base Cap from the Base. Vigorously tap the plate on a stack of absorbent paper, and blot the nozzles of the EZ-10 Binding Plate with clean adsorbent paper until no droplets remain.
15. For optimal results, incubate at 60°C for 15 minutes to allow ethanol to evaporate completely.
16. For elution, assemble the vacuum manifold. Place a Deep Well Collection Plate (can be a used one) in the Base. Place a 96 Well Storage Plate on top, and cover it with Base Cap. Place EZ-10 96 Well Binding Plate on top securely. Mark the orientation properly.
17. To elute DNA, pipette 50 µl of Elution Buffer into the center of each well of the EZ-10 96 Well Binding Plate, incubate for 1 to 5 minutes, and apply vacuum (–550 to –650 mbar) for 1 minute. Switch off vacuum and ventilate vacuum manifold slowly.
18. Tightly seal the 96 Well Storage Plate. Plasmid DNA is ready for use or store at -20°C freezer.

6. Spin down at 4,500 x g for 15 minutes following step 5.
7. Assemble the vacuum manifold. Place the block at the bottom of the base. Then place a new Deep Well Collection Plate on top of the block; cover unit with the Base Cap. Place a clean 96 Well Filter Plate (blue nozzle) on top.
8. Pipette the supernatant from step 5 carefully into the wells of the 96 Well Filter Plate. Apply vacuum until all samples have passed through. Do not pipette any debris into the 96 Well Filter Plate as they may clog the wells. Collect and save lysate in the Deep Well Collection Plate.

NOTE: This step will efficiently remove any cell debris from lysate. Desired DNA will be collected in the Deep Well Collection Plate.
9. Assemble the vacuum manifold. This time, place a Waste Tray in the Base, cover it with the Base Cap, and put a clean EZ-10 96 Well Binding Plate (pink nozzle) on top.
10. Pipette the lysates carefully from step 7 into the wells of an EZ-10 96 Well Binding Plate. Apply vacuum until all samples have passed through.
11. Switch off the vacuum and ventilate the vacuum manifold slowly. Add 600 μ l Wash Solution to each well and apply vacuum until buffer has passed through.

Procedures

1. Fill each well of a Deep Well Collection Plate with 1.3 ml of growth medium containing the appropriate selective antibiotic. Inoculate each well from a single bacterial colony. Incubate the cultures for overnight or 20-24 hours at 37°C with shaking at 300 rpm.

NOTE: The wells in the block may be protected against spill-over by covering the block with a plastic lid or adhesive tape. If non-porous tape is used, pierce 2–3 holes in the tape with a needle above each well for aeration. For optimal DNA yield, use 1.5-5 ml overnight culture to start.

2. Harvest the bacterial cells in the Deep Well Collection Plate by centrifugation for 10 minutes at 5,788 x g in a centrifuge with a rotor for microtiter plates. The Deep Well Collection Plate should be covered with Sealing Film during centrifugation. Remove medium by inverting the Deep Well Collection Plate.

NOTE: To remove the media, peel off the Sealing Film and quickly invert the Deep Well Collection Plate over a waste container. Tap the inverted Deep Well Collection Plate firmly on a paper towel to remove any residues.

3. Resuspend each well of bacterial cells in 100 μ l Solution I. Tape the Deep Well Collection Plate with a new Sealing Film. Vortex for approximately 3 minutes.

NOTE: Ensure that RNase A has been added to Solution I. The pelleted cells in the Deep Well Collection Plate must be resuspended completely, leaving no cell clumps.

4. Add 200 μ l of Solution II to each well, seal the Deep Well Collection Plate with a new Sealing Film, mix gently but thoroughly by inverting 10 times and incubate for 2 minutes.

NOTE: Do not vortex at this step to avoid shearing of the bacterial genomic DNA. Do not incubate for more than 5 minutes. Additional incubation can result in increased levels of open circular plasmid DNA. At the end of the incubation, the lysate should appear viscous and free of bacterial cell clumps. Avoid extended exposure of Solution II to air since CO₂ can reduce its effectiveness.

5. Add 350 μ l Solution III to each well, seal the Deep Well Collection Plate with Sealing Film, and mix immediately by inverting 10 times and incubate for 3 minutes.

NOTE: Gently invert the taped Deep Well Collection Plate 10 times to ensure uniform precipitation. To seal, completely dry the block with a paper towel, take a new Sealing Film and seal tightly either manually or using a sealing roller.

6A. (OPTIONAL)

Remove the Sealing Film from the Deep Well Collection Plate and add 300 μ l isopropanol to each well. Seal the plate firmly with a new Sealing Film. Mix by inverting the plate 1-2 times. Further inversions are not required and may cause leakage of the isopropanol. Ensure that the plate is tightly sealed to avoid cross-contamination of wells. If the plate is loosely sealed, the isopropanol can cause the sealing film to detach from the plate.

Vacuum Based Procedure

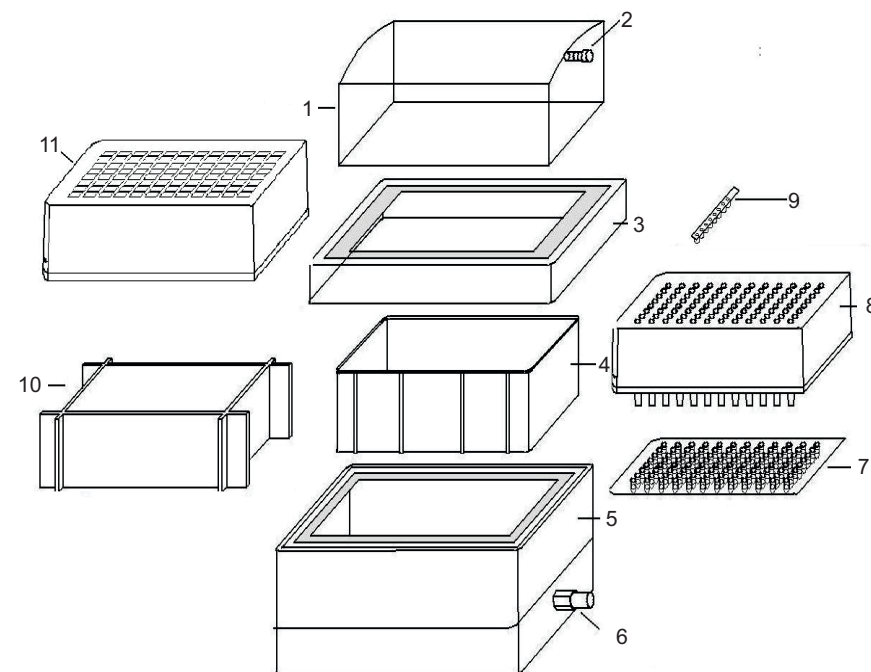

Figure 1. Components of EZ-10 96 Well Spin Column Plasmid DNA Minipreps Kit

- | | |
|---------------------|---------------------------------------------------------------------------------|
| 1. Top Cap | 7. 96 Well Storage Plate |
| 2. Release Valve | 8. 96 Well Filter Plate (blue nozzle) or
96 Well Binding Plate (pink nozzle) |
| 3. Base Cap | 9. 8 Well Strip Vacuum Sealer |
| 4. Waste Tray | 10. Block |
| 5. Base | 11. Deep Well Collection Plate |
| 6. Vacuum Connector | |

Note: Vacuum Manifold (F505011-0001– including 1- 6, 10) and 8 Well Strip Vacuum Sealer (BP547) are sold separately.